



FRIGOMATIC

the 12/24V refrigeration systems for boats

- Easy to install and maintain
- Wide range of solutions
- **Unique re-sealing 'quick couplings' system**
- Best efficiency and lowest power consumption



Built to the highest specification and designed for self-installation, Frigomatic refrigeration systems deliver **the best performance**. 12V or 24V DC fridge or freezer system with the lowest power consumption, whether air cooled, keel cooled or pump water cooled.

Frigomatic has a **wide range** of evaporator plates and either air cooled, keel cooled or pump water cooled condensing sets to optimize the fridge or freezer system in an existing insulated cool box.

Easy to install with all the components pre-charged with refrigerant and connected by Frigoboat's unique re-sealing 'quick couplings' system and controlled with either mechanical or digital thermostats.

Costruiti per applicazioni nautiche e per un'installazione semplice, i sistemi di refrigerazione Frigomatic sono studiati per ottenere sempre il miglior rapporto tra **resa ed efficienza energetica**. Studiati per applicazioni a 12V o 24V, per ottimizzare i consumi, sia nella versione ad aria che nelle versioni con raffreddamento ad acqua.

La linea Frigomatic offre inoltre un **ampia scelta** di evaporatori, e di motocondensanti per ottimizzare e studiare in modo ottimale l'impianto frigo/freezer di bordo.

Facili da installare, tutti i componenti dei kit Frigomatic sono precaricati e dotati dell'innovativo sistema ad innesti rapidi, riutilizzabili, e controllati da termostati meccanici o digitali.



BEST EFFICIENCY
WITH LOW POWER



WIDE RANGE
OF SOLUTIONS



UNIQUE RE-SEALING
QUICK COUPLINGS



EASY TO INSTALL
AND MAINTAIN

1 | Calculate the volume of the fridge/freezer

Calcola il volume del vano da refrigerare

$$\text{Volume} = \frac{D \times W \times H}{1000}$$

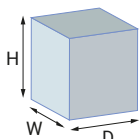

2 | Select the thermostat that best fits your system

Scegli il termostato più adatto al tuo sistema

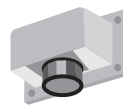

3 | Select the most suitable condensing unit

Scegli la motocondensante più adatta

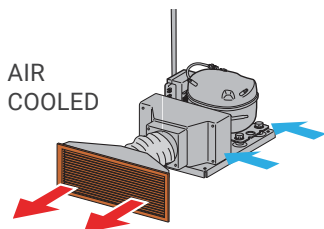

AIR COOLED

AIR COOLED | Raffreddamento ad aria

An air-cooled system is less efficient than a water cooled system but is cheaper and easier to install. To achieve maximum energy efficiency, the air is conveyed to an aluminum fin condenser. Choose air cooled for Northern European cruising.

Un sistema con raffreddamento ad aria è meno efficiente di uno ad acqua, ma è più economico e più semplice da installare a bordo. Per ottenere la massima efficienza, l'aria viene convogliata in uno scambiatore alettato. Scegli un sistema ad aria per navigazioni in clima nord-europeo o mediterraneo.

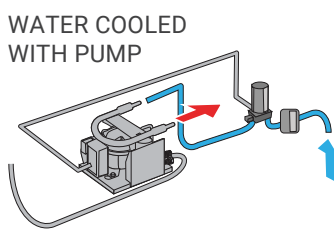

WATER COOLED WITH PUMP

WATER COOLED | Raffreddamento ad acqua

A water-cooled system is more efficient than an air cooled one because water dissipates heat far better than air. Moreover, keel cooling is also more efficient, reliable and quieter than a pump water cooled system as the only moving part required is the compressor. Choose a water cool if you are planning to cruise the Mediterranean or Tropics.

Un sistema con raffreddamento ad acqua è più efficiente di un sistema ad aria perchè l'acqua dissipa il calore molto più velocemente. Un sistema a fuoriscafo è ancora più efficiente, affidabile e silenzioso rispetto al raffreddamento a pompa, perchè l'unico componente in movimento rimane il compressore. Scegli un sistema ad acqua per navigazioni in clima mediterraneo o tropicale.

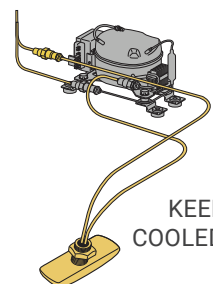

KEEL COOLED

4 | Choose the evaporator that best suits your box

Scegli l'evaporatore più adatto al tuo vano

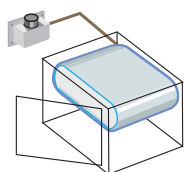

SERIES H
Ice Box

Ideal for fridges with freezer compartments within a fridge; mounted vertically or horizontally, supplied with lid.

Ideale per frigo con vano freezer a celletta per montaggio verticale od orizzontale. fornito con chiusura.

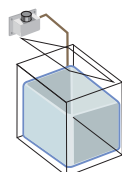

SERIES B
Bended

Ideal for fridges with freezer compartments or as dedicated freezer; mounted vertically or horizontally.

Ideale per frigo con vano freezer, o come freezer dedicati, per montaggio verticale od orizzontale.

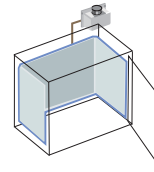

SERIES F
Flat

Ideal for top loading fridges or freezers; flat evaporators can be used flat or bent to fit around the inside of the box.

Ideale per frigo o freezer a pozzetto possono essere usati piatti, o piegati per seguire la forma della del vano.

MECHANICAL THERMOSTATS



Mechanical Frigoboat
fridge thermostat



Mechanical Frigoboat
freezer thermostat

DIGITAL THERMOSTATS



Digital Frigoboat
fridge-freezer thermostat

	Type	Power Supply	Code	Speed regulator	Fridge capacity (lt)	Freezer capacity (lt)	Net weight (kg)	Gross weight (kg)	Size (WxDxH)
MADRID 35 F	Air cooled	12/24V	E51380	NO	100	n.a.	5,80	6,80	231x128x288
PARIS 35F	Air cooled	12/24V	E51135	NO	100	n.a.	6,30	7,30	230x300x168
ROMA 35 F	Air cooled	12/24V	E51275	NO	100	n.a.	6,20	7,20	345x205x171
FM100	Air cooled	12/24V	E52270	NO	100	n.a.	6,30	7,30	200x224x169
ELBA 35F	Air cooled	12/24V	E51435	YES	200	70	7,40	8,40	326x238x169
CAPRI 35F	Air cooled	12/24V	E51430	YES	200	70	8,50	9,50	283x213x170
FM 200	Air cooled	12/24V	E52375	YES	200	70	7,40	8,40	300x180x164
AH 35 F	Air cooled	12/24V	E50035X	YES	340	70	6,30	7,30	332x220x166
AV 35 F	Air cooled	12/24V	E50025X	YES	340	70	6,30	7,30	218x165x297
CAPRI 50 F	Air cooled	12/24V	E52120	YES	340	80	8,50	9,50	283x213x170
K 35 F	Keel cooled	12/24V	E50345X	YES	340	100	5,80	6,80	260x145x170
K 50 F	Keel cooled	12/24V	E51975	YES	380	100	5,80	6,80	260x145x170
W 35 F	Water cooled	12/24V	E50045X	YES	340	100	5,80	6,80	260x160x180
W 50 F	Water cooled	12/24V	E51970	YES	380	100	5,80	6,80	260x160x180

115V - 230V AC VERSIONS

	Type	Power Supply	Code
FM 200 AC	Air cooled	115/230AC - 12/24V	E20035AC
AV 35F AC	Air cooled	115/230AC - 12/24V	E53090
CAPRI 35F AC	Air cooled	115/230AC - 12/24V	ECAPRI35AC
CAPRI 50 AC	Air cooled	115/230AC - 12/24V	ECAPRI50AC
MADRID 35 F AC	Air cooled	115/230AC - 12/24V	EMADRID35AC
K 35 F AC	Keel cooled	115/230AC - 12/24V	EK35AC
K 50 F AC	Keel cooled	115/230AC - 12/24V	EK50AC
W 35 F AC	Water cooled	115/230AC - 12/24V	EW35AC
W 50 F AC	Water cooled	115/230AC - 12/24V	EW50AC



Code	Diameter	Zincs	Thread lenght	Size (mm)	Description
E50361	38 mm	No	45 mm	175 x 130 x 22*	Keel cooler with short thread, no zincs
E50361Z	38 mm	Yes (x2)	45 mm	175 x 130 x 22*	Keel cooler with short thread, with zincs
E50362	38 mm	No	105 mm	175 x 130 x 22*	Keel cooler with long thread, no zincs
E50362Z	38 mm	Yes (x2)	105 mm	175 x 130 x 22*	Keel cooler with long thread, with zincs

The **Frigoboat Keel cooler** uses the water on the outside of the hull to cool and condense the refrigerant in the system; produced in marine bronze, the sintered plate protects the heat exchanger from damage; while offering the best efficiency in terms of heat exchanging capabilities.

The internal heat exchanger is manufactured from marine copper-nickel for maximum resistance against sea water corrosion.

Frigoboat keel cooler is similar to a regular through-hull fitting. Its threaded, 38 mm diameter shaft passes through the hull, and a nut is threaded onto the shaft and tightened. It is available in 2 versions, one with short thread and one with a longer thread; both models can be ordered with or without sacrificial zincs to further protect the system from galvanic corrosion.

L'innovativo sistema a **fuoriscafo Frigomatic** usa l'acqua di mare che sfiora lo scafo per la condensazione dell'impianto frigorifero stesso. Studiati in bronzo adatto ad ambiente marino, la piastra sinterizzata protegge lo scambiatore di calore da danni e ne aumenta l'efficienza di scambio termico.

Lo scambiatore di calore all'interno, in cupro-nickel marino, massimizza la resistenza alla corrosione.

Simile ad una presa per acqua mare, il fuoriscafo Frigomatic, passante a scafo, ha un diametro di 38 mm, e viene fissato tramite un dado filettato.

Disponibile in due versioni, con filetto lungo o corto, entrambi i modelli possono essere forniti con o senza zinchi, per proteggere ulteriormente l'impianto da corrosione galvanica.

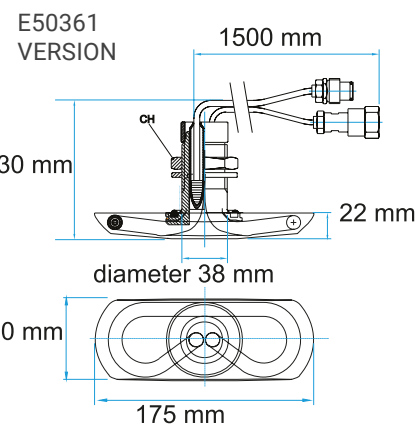

WITH OR WITHOUT ZINCS?

Both keel cooler models are available with or without sacrificial zincs. Zincs are installed on the keel cooler itself, flush with the surface.

If the keel cooler is already connected electrically to the boat's sacrificial zinc, then the zincs are not needed, while if the boat does not have a bonding system it would be advisable to use a keel cooler with zincs.

CON O SENZA ZINCHI?

Tutti i modelli fuoriscafo Frigomatic sono disponibili in versione con o senza anodi sacrificali. Gli zinchi sono installati sul fuoriscafo stesso, a filo con la sua superficie.

Se il fuoriscafo è già connesso agli anodi dell'imbarcazione, allora non è necessario aggiungerli al fuoriscafo, mentre nel caso in cui manca un sistema di messa a terra, è suggerita l'installazione con zinchi.

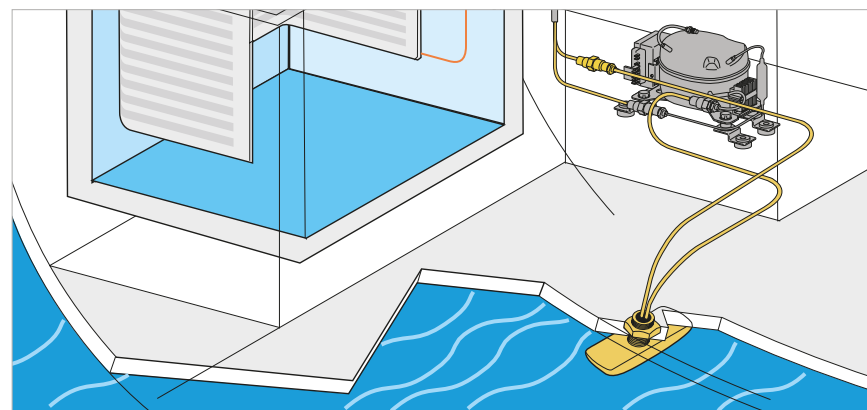

	Serie	Fridge capacity	Freezer capacity	Code	Pipe material	Bendable	Installation	SIZE (mm)	Net weight (Kg)	Shipping weight (Kg)
160H	H - Ice box	200 Lt	80 Lt	E52475	aluminium	no	Vertical & Horiz.	320x115x210	1,5	2,4
130H	H - Ice box	120 Lt	50 Lt	E50065	copper	no	Vertical & Horiz.	255x70x210	1,3	1,8
160H	H - Ice box	200 Lt	80 Lt	E50090	copper	no	Vertical & Horiz.	320x115x210	1,5	2,4
200H	H - Ice box	200 Lt	80 Lt	E50070	copper	no	Vertical & Horiz.	360x150x270	2,2	2,9
200B	B - Bended	220 Lt	80 Lt	E50100	copper	yes	Vertical & Horiz.	325x270x245	2,2	3
250B	B - Bended	250 Lt	80 Lt	E51625	copper	yes	Vertical & Horiz.	250x285x160	1,6	2,4
340B	B - Bended	340 Lt	80 Lt	E50105	copper	yes	Vertical & Horiz.	380x290x150	2,2	3
80F	F - Flat	80 Lt	n.a.	E50883	aluminium	yes	Horizontal	330x245x5	1,1	2,5
130F	F - Flat	160 Lt	60 Lt	E50085	copper	yes	Horizontal	590x210x5	1,2	2,5
160F	F - Flat	180 Lt	70 Lt	E52480	aluminium	yes	Horizontal	805x210x5	1,4	2,4
160F	F - Flat	180 Lt	70 Lt	E50095	copper	yes	Horizontal	805x210x5	1,4	2,4
200F	F - Flat	240 Lt	80 Lt	E50075	copper	yes	Horizontal	1020x270x5	1,5	2,5
380F	F - Flat	380 Lt	100 Lt	E52225	copper	yes	Horizontal	950x365x5	2,1	3,3
180F inox	F - Flat	180 Lt	70 Lt	E52105	copper	yes	Horizontal	590x305x8	2,2	2,8
380F inox	F - Flat	380 Lt	80 Lt	E52185	copper	yes	Horizontal	1020x410x8	3,2	3,8

Supplied with 2,8 mt of pre-charged, copper refrigerant pipe as standard, all Frigomatic evaporators are provided with **Frigoboat self-sealing couplings**. Available in 3 different models, each with a wide range of sizes, Frigomatic evaporators can satisfy every installation requirement.

Gli evaporatori sono già precaricati, con tubazoni in rame da 2.8mt; e sono tutti studiati con **innesti rapidi Frigoboat** per un'installazione semplice. Disponibili in 3 diversi tipologie, ciascuna con un'ampia gamma di taglie, permettono di soddisfare qualsiasi esigenza di installazione.



EXTENSION PIPES

A full range of extension pipes fitted with Frigoboat self-sealing couplings allows to locate your Frigomatic condensing unit up to 6 meters from the evaporator.

Una gamma completa di prolunghe, tutte dotate di innesti rapidi Frigoboat, permettono di poter installare il Frigomatic fino a 6 metri dal vano refrigerato.

FRIGOMATIC SEA WATER PUMP AND STRAINER

Self-priming pump specifically designed for Frigomatic water cooled systems, self-priming up to 2 mt, it can be used for cooling up to 3 units adding a pump interface or a relay. Pumps needs a sea water strainer; the Frigoboat one comes with a stainless steel support.

La pompa autoadescante Frigomatic, ideale per impianti Frigoboat, con una prevalenza fino a 2mt, può essere usata fino a 3 motocondensanti Frigomatic, utilizzando l'interfaccia pompa Frigomatic o un sistema a relè.

FRIGOMATIC PUMP INTERFACE

The Frigoboat pump interface is a useful accessory when more Frigomatic units are connected to the same pump.

L'interfaccia pompa Frigomatic permette di collegare fino a 3 motocondensanti ad un'unica pompa Frigomatic a 12V.



VOLTAGE DIVIDER

The Frigoboat pump interface is a very useful when more Frigomatic units are connected to the same pump.

L'interfaccia pompa Frigomatic permette di collegare fino a 3 motocondensanti ad un'unica pompa Frigomatic.



COMPRESSOR SPEED REGULATOR

Mounts on compressor controller, the Speed Regulator is a manual compressor speed adjustment device (standard on most Frigomatic units).

Montato sul controllo compressore, il Regolatore permette di modificare la velocità manualmente (standard su quasi tutti i modelli Frigomatic).



230V CONTROLLER OPTION

Optional electronic controller studied to work also with a 230V/50-60 and 115V/50-60 power supply; the controller can automatically switch power supply, so when mains is available, this device automatically excludes the battery supply and runs the compressor from mains.

Controllo elettronico per Frigomatic che permette di alimentare il sistema a 230V/50-60 o 115V/50-60; quando l'alimentazione principale è disponibile il dispositivo esclude automaticamente l'alimentazione da batteria e utilizza l'alimentazione principale.

